



**ON Semiconductor®**

# Understanding Digitally Programmable Potentiometers

**Fundamentals of Digitally Programmable Potentiometers (DPP)  
and design ideas for applications**

# Architectural Overview

- The digital potentiometer is a mixed signal device designed as an electronic replacement for mechanical potentiometers. The function of the potentiometer section of the electronic potentiometer is the same as the mechanical version. In both cases, the potentiometer or pot is a three terminal device.
- Between two of the terminals there is a resistive element. The third terminal called the wiper is connected to various points along this resistive element.

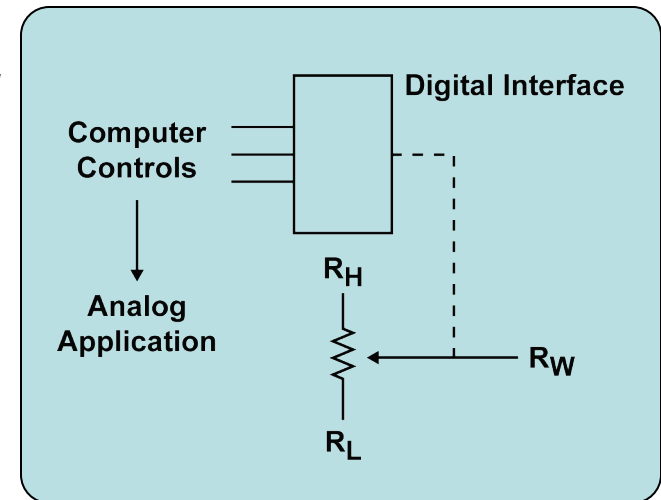

# Digital Potentiometers (DPPs)

## Mechanical Potentiometer

- Consists of a resistor and a third terminal called the *wiper*
- The wiper divides the resistor
- The position of the wiper is adjusted mechanically – e.g. using a screwdriver

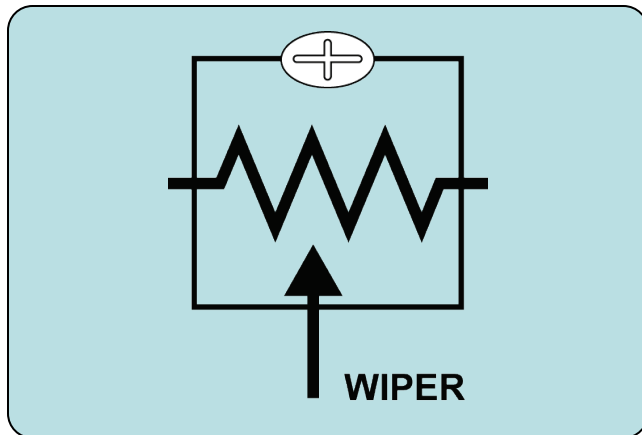

## Digital Potentiometer

- Fulfills the same function
- The position of the wiper is adjusted via serial interface
- The wiper can move through a discrete number of steps (taps)

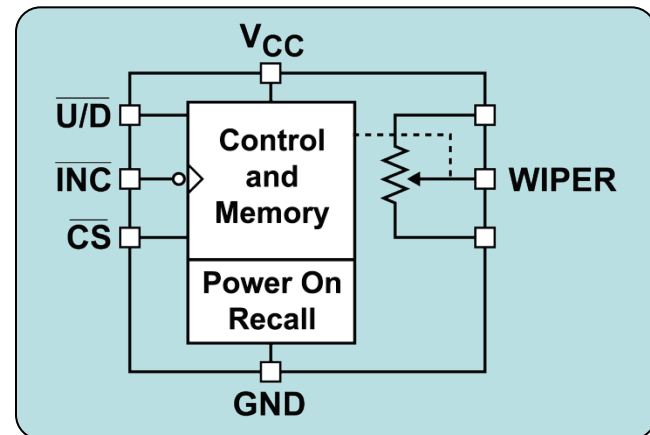

# Potentiometer Basic Functionality



## Applications

- Volume Adjustment
- Frequency Attenuation
- Brightness Adjustment
- Contrast Adjustment
- Voltage Trimming
- Joysticks
- Motor control
- Automated calibration

# Mechanical Potentiometers vs. DPPs

Mechanical Potentiometers	DPPs
Negligible wiper resistance	Wiper resistance $\sim 100 \Omega$
Well controlled end-to-end resistance	End to end resistance process-dependent: $\pm 20\%$ tolerance <ul style="list-style-type: none"><li>• <b>BUT</b> ratio between wiper positions constant</li></ul>
Cumbersome mechanical interface	Can be controlled by microprocessors or push buttons via standard serial interfaces: <ul style="list-style-type: none"><li>• I<sup>2</sup>C</li><li>• SPI</li><li>• Up/Down</li><li>• Inc/Dec</li></ul>



# Main Distinguishing Features

## Memory

- Volatile DPP resets the wiper at mid-scale on power-on. Although they don't have internal non-volatile storage, volatile DPP provides a cost-effective solution by using the storage capability already existent within the application.
- The non-volatile DPP has an EEPROM for wiper storage, thus recalling the wiper position at power-on. This feature simplifies applications that require the wiper position to be automatically saved (for example, saving the last user setting).

## Control Interface

- Most common asynchronous bus is the increment/decrement interface
- The most common synchronous bus is I<sup>2</sup>C.

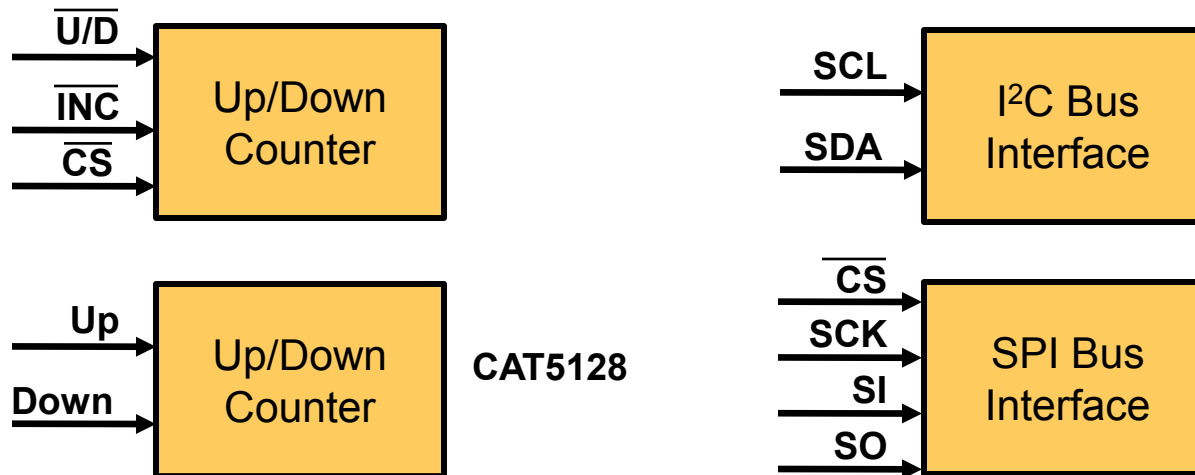

# Adjustable Gain Circuit with Rheostat

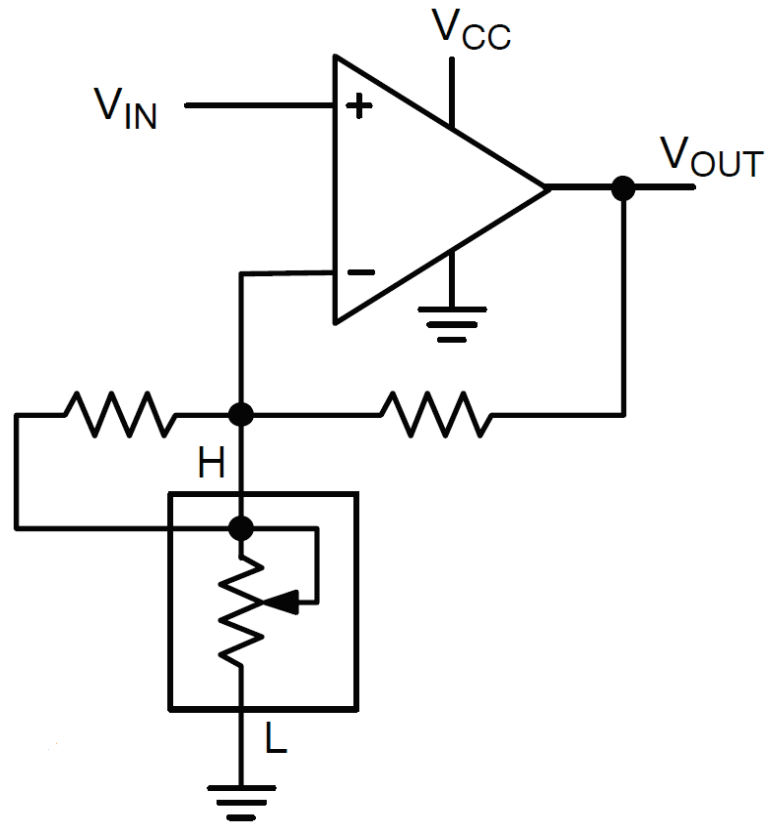

# Adjustable Gain Circuit with Voltage Divider

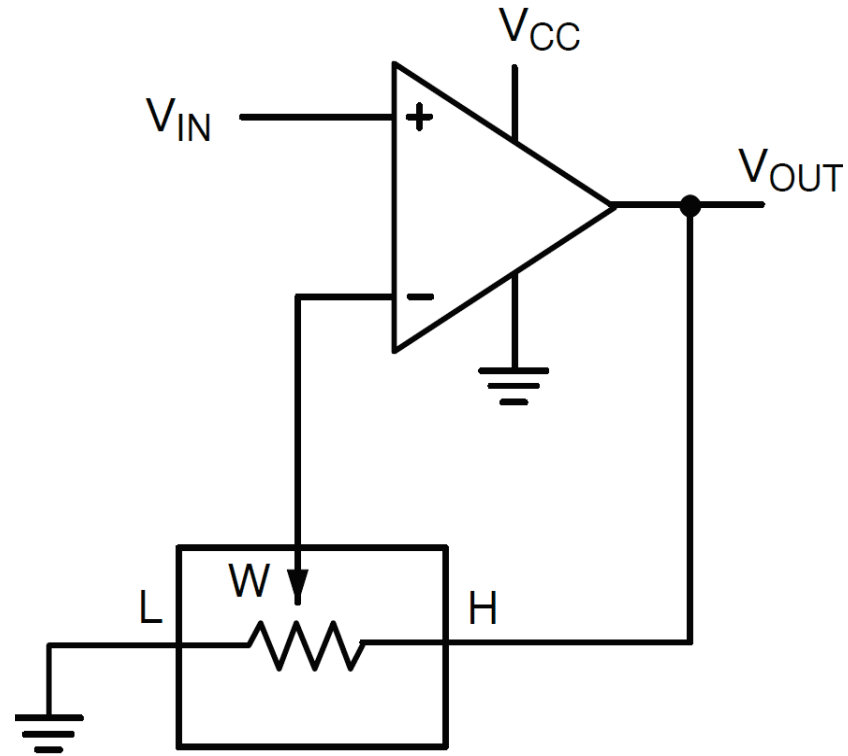



# Positive LCD Bias Control

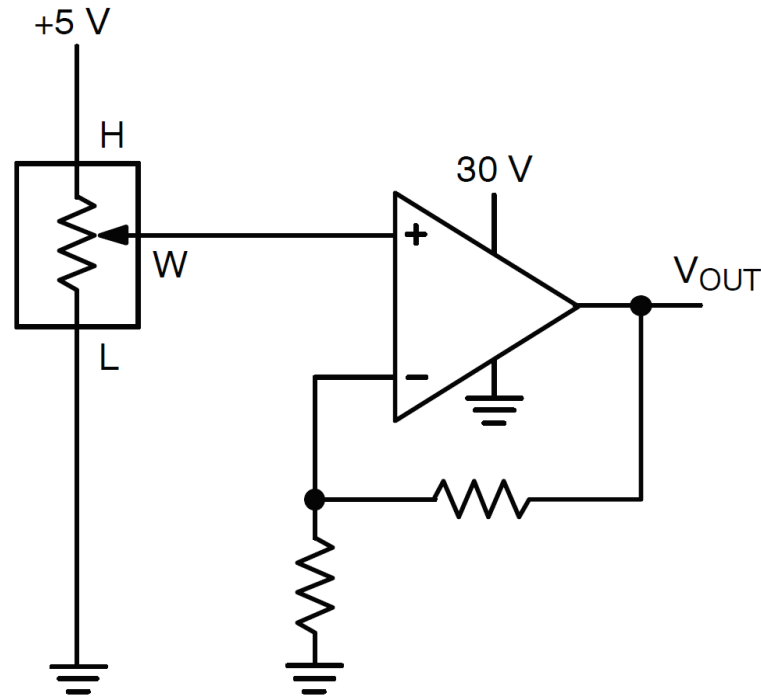

# Programmable Instrumentation Amplifier

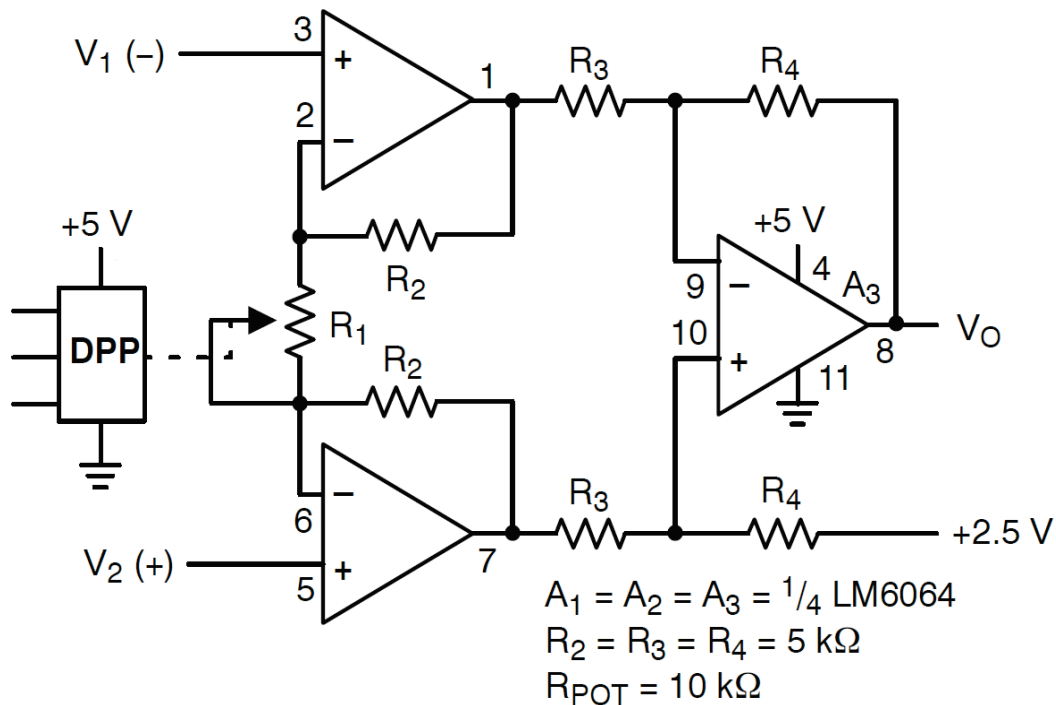

# Programmable Square Wave Oscillator

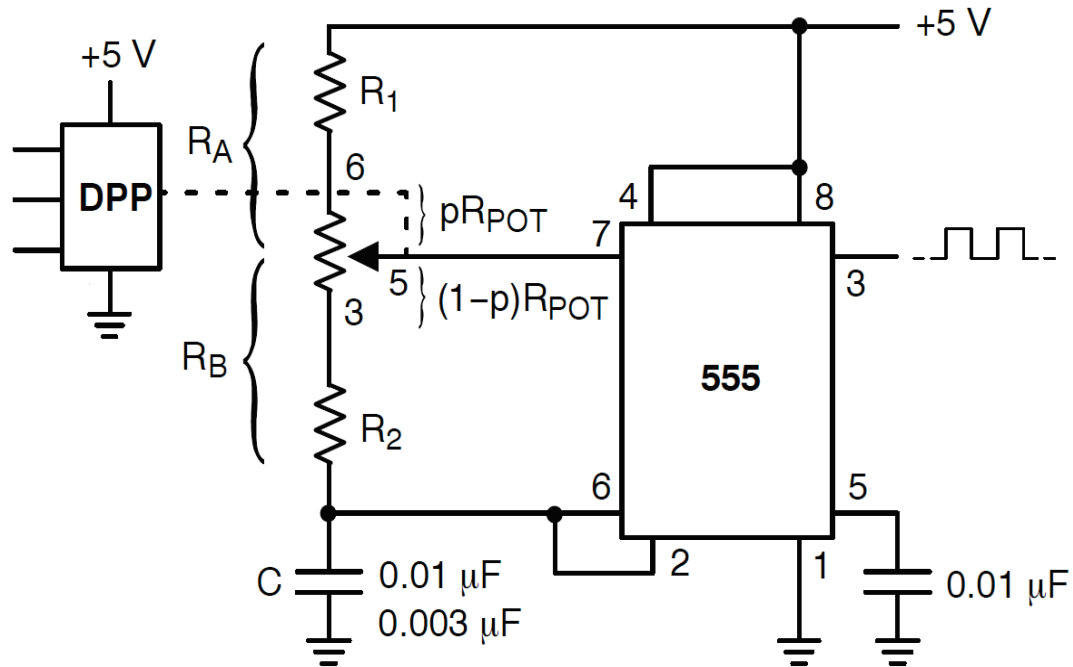

# Programmable Voltage Regulator

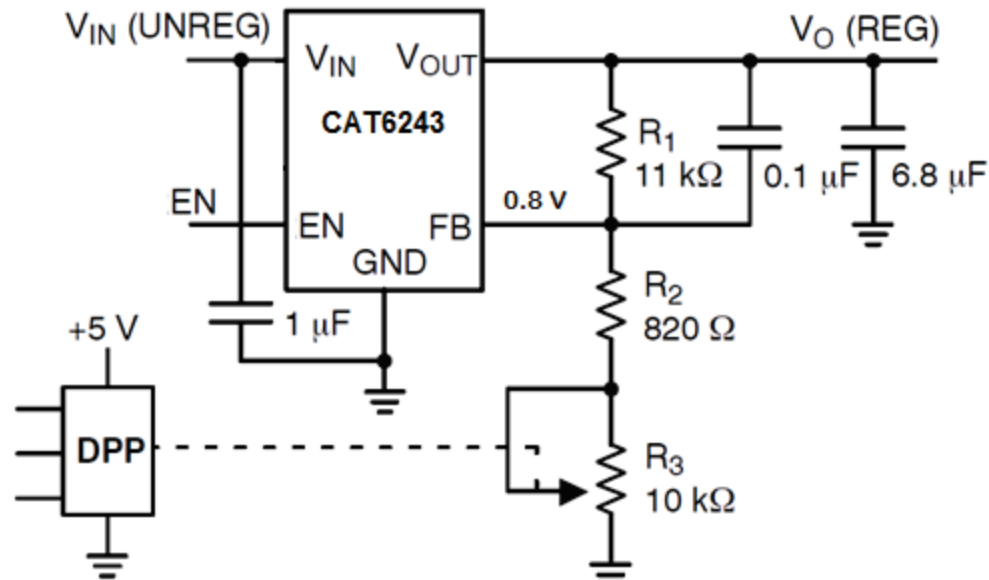

# Sensor Auto Referencing Circuit

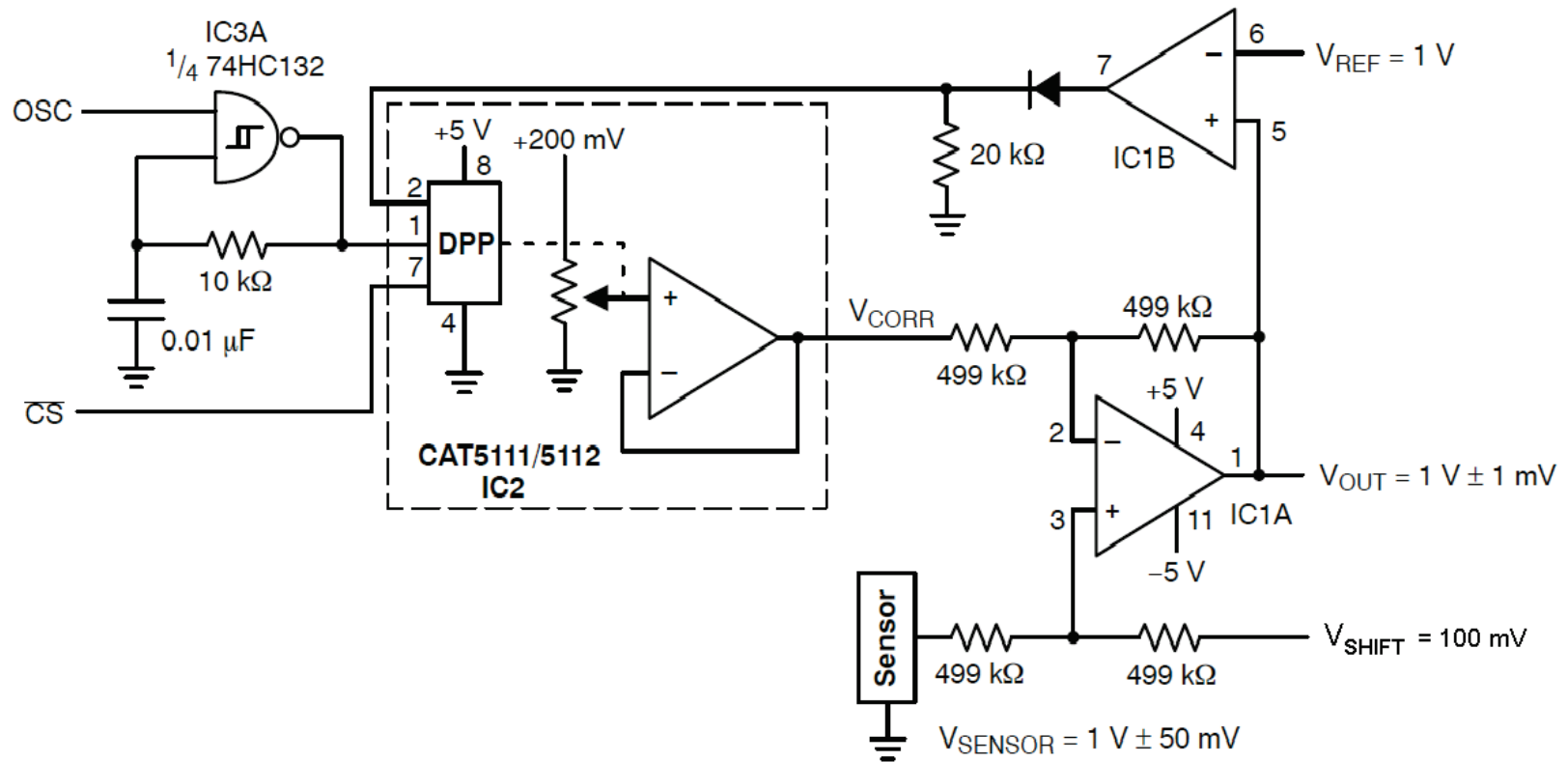

# Programmable I to V Converter

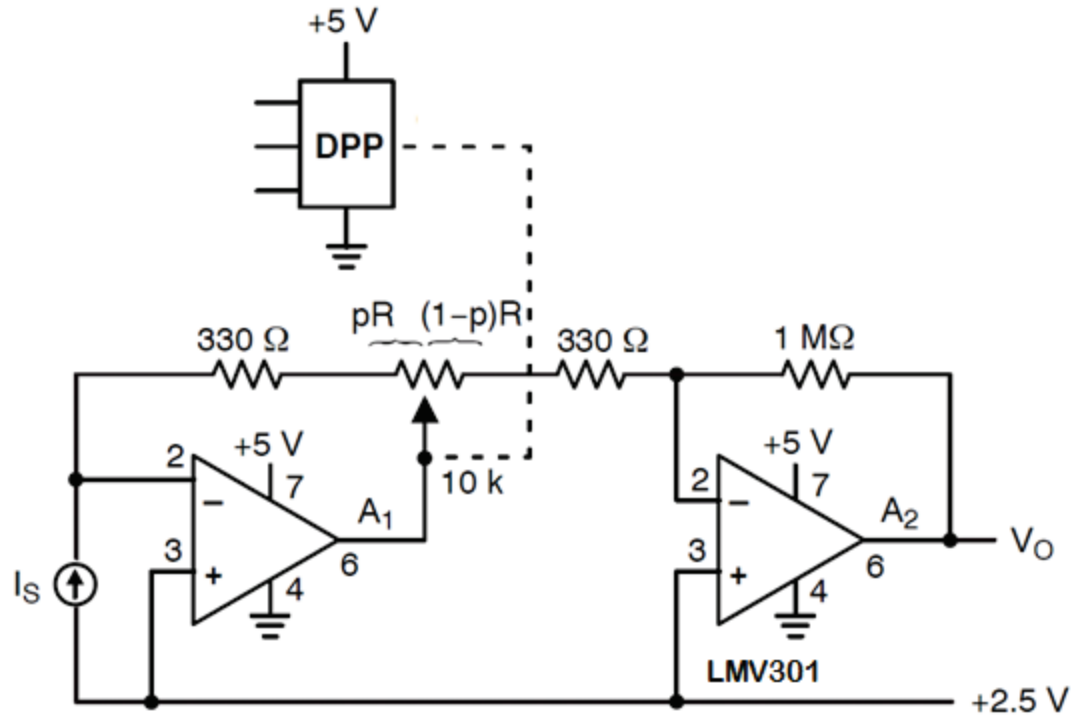

# Automatic Gain Control

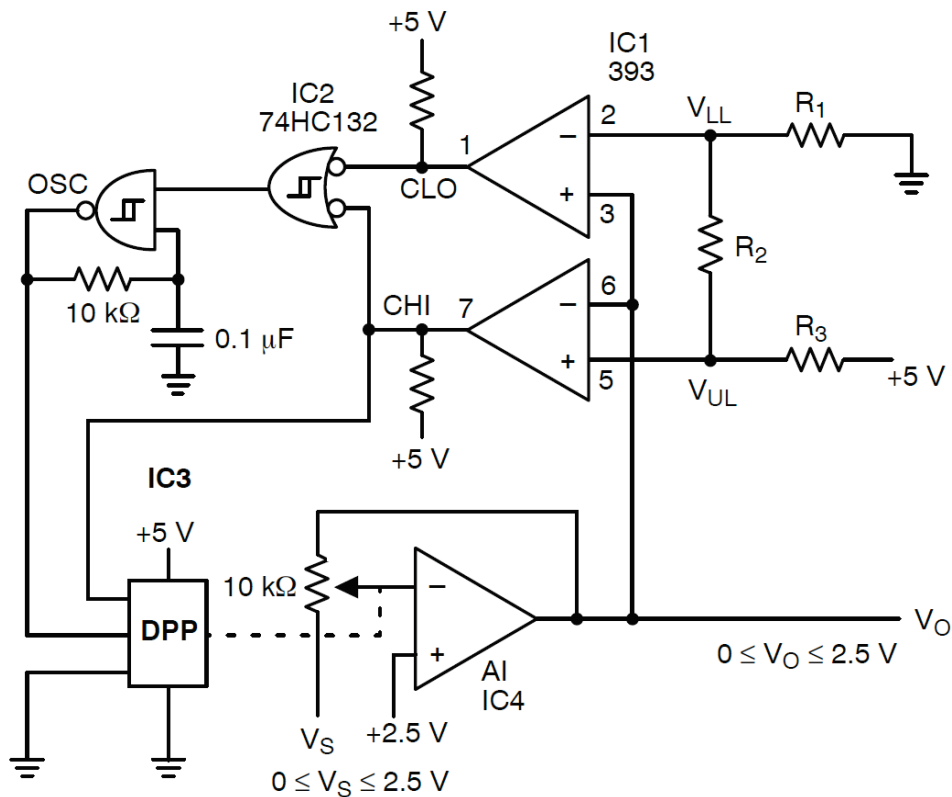

# Programmable Current Source/Sink

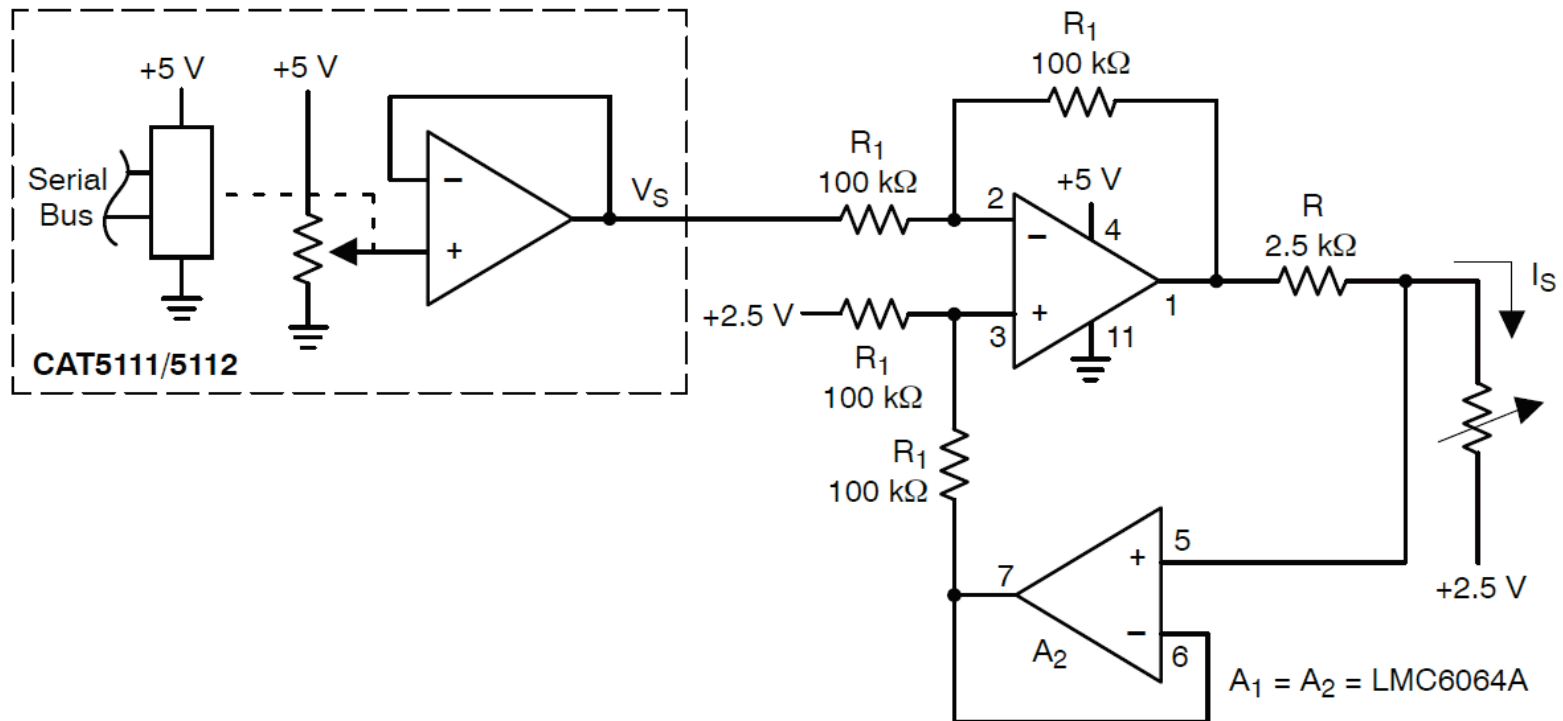



# For More Information

- View the extensive ON Semiconductor portfolio of products for energy efficient electronics at [www.onsemi.com](http://www.onsemi.com).

