

Dual SIM Smart Card
 Power Supply and Inter-

DESCRIPTION

Demonstration circuit 1263 is a Dual SIM Smart Card Power Supply and Interface featuring the LTC4558.

The LTC[®]4558 provides the power conversion and signal level translation needed for advanced cellular telephones to interface with 1.8V or 3V subscriber identity modules (SIMs). The device meets all requirements for 1.8V and 3V SIMs and contains LDO regulators to power 1.8V or 3V SIM cards from a 2.7V to 5.5V input. The output voltages can be set using the two voltage selection pins and up to 50mA of load current can be supplied. A channel select pin determines which channel is open for communication. Separate enable pins for each channel allow both cards to be

powered at once and allow for faster transition from one channel to the other.

Internal level translators allow controllers operating with supplies as low as 1.4V to interface with 1.8V or 3V Smart Cards. Battery life is maximized by a low operating current of 65 μ A and a shutdown current of less than 1 μ A. Board area is minimized by the low profile 3mm \times 3mm \times 0.75mm leadless QFN package.

Design files for this circuit board are available. Call the LTC factory.

L, LTC, LT, are registered trademarks of Linear Technology Corporation. Other product names may be trademarks of the companies that manufacture the products.

 PERFORMANCE SUMMARY Specifications are at $T_A = 25^\circ\text{C}$

PARAMETER	CONDITIONS	MIN	TYP	MAX	UNITS
V_{BATT} Input Supply Range		2.7		5.5	V
DV_{CC} Input Supply Range		1.4		5.5	V
$V_{CCA,B}$ Output Voltage Range	3V Mode, $0\text{mA} < I_{CCA,B} < 50\text{mA}$ 18V Mode, $0\text{mA} < I_{CCA,B} < 50\text{mA}$	2.85 1.71	3.00 1.8	3.15 1.89	V V
CLOCKA,B FREQUENCY		10			MHz
CLOCKA,B RISE/FALL TIME	Loaded with 50pF (10% to 90%)			16	ns
CLOCKA,B LOW LEVEL OUTPUT	Sink Current = -200 μ A			0.2	V
CLOCKA,B HIGH LEVEL OUTPUT	Source Current = 200 μ A	$V_{CCA,B} - 0.2$			V
RSTA,B LOW LEVEL OUTPUT	Sink Current = -200 μ A			0.2	V
RSTA,B HIGH LEVEL OUTPUT	Source Current = 200 μ A	$V_{CCA,B} - 0.2$			V
I/OA,B LOW LEVEL OUTPUT	Sink Current = -1mA ($V_{DATA} = 0\text{V}$)			0.3	V
I/OA,B HIGH LEVEL OUTPUT	Source Current = 20 μ A ($V_{DATA} = V_{DVCC}$)	$0.85 \cdot V_{CCA,B}$			V
DATA LOW LEVEL OUTPUT	Sink Current = -500 μ A ($V_{I/OA,B} = 0\text{V}$)			0.3	V
DATA HIGH LEVEL OUTPUT	Source Current = 20 μ A ($V_{I/OA,B} = V_{CCA,B}$)	$0.8 \cdot DV_{CC}$			V
LOW LEVEL INPUT (V_{IL})				$0.15 \cdot DV_{CC}$	V
HIGH LEVEL INPUT (V_{HL})		$0.85 \cdot DV_{CC}$			V

QUICK START PROCEDURE

Demonstration circuit 1263 is easy to set up to evaluate the performance of the LTC4558. Refer to Figure 1 for proper measurement equipment setup and follow the procedure below:

NOTE. When measuring the input or output voltage ripple, care must be taken to avoid a long ground lead on the oscilloscope probe. Measure the input or output voltage ripple by touching the probe tip directly across the VBATT, VCCA, or VCCB and GND terminals. See Figure 2 for proper scope probe technique.

1. Place jumpers in the following positions:

JP1 ENABLEA: LO

JP2 VSELA: HI

JP3 CSEL: LO

JP4 CLKRUNA: LO

JP5 CLKRUNB: LO

JP6 VSELB: HI

JP7 ENABLEB: LO

2. With power off, connect the input power supply (PS1), capable of supplying at least 200mA, to VBATT and GND terminals.

3. With power off, connect the input power supply (PS2) to DVCC and GND terminals. If desired, a single supply may be used for VBATT and DVCC providing the supply is set within the VBATT operating range.

4. Turn on the PS1 power supply and set the voltage between 2.7V and 5.5V.

NOTE. Make sure that the input voltage does not exceed 6V.

5. If using two power supplies, turn on the PS2 power supply and set the voltage between 1.4V and 5.5V.

NOTE. Make sure that the input voltage does not exceed 6V.

6. If SIM/Smart Cards are to be used for evaluation, insert cards into one or both card sockets.

7. To enable one or both of the card sockets, move the ENABLEA and/or ENABLEB jumpers to the HI position.

8. The VCCA or VCCB voltages may be selected by changing the positions of the VSELA or VSELB jumpers, respectively.

9. Move the CSEL jumper to the LO position to communicate with Card Socket A, or the HI position to communicate with Card Socket B.

10. The CLOCK, DATA and RESET channels may be tested by applying signals to the CLKIN, DATA and RSTIN pin and observing the outputs of the selected card socket.

11. The CLKRUNA and CLKRUNB pins may be set HI if the user desires to continue to send the clock signal to a card socket after it has been deselected. The card socket's ENABLE pin must be set HI for this function to work.

The user has the option of controlling the inputs externally, rather than by using the on-board jumpers. To do this, the jumpers should be removed and external signal sources (e.g. microcontroller outputs) should be connected to the associated terminals on the board.

The RSTIN, CLKIN, ENABLEA, ENABLEB, VSELA, VSELB, CLKRUNA, CLKRUNB and CSEL inputs all possess external 100kΩ pull down resistors (R1 through R9) to prevent them from floating. These resistors may be removed if the inputs are controlled with an external signal source.

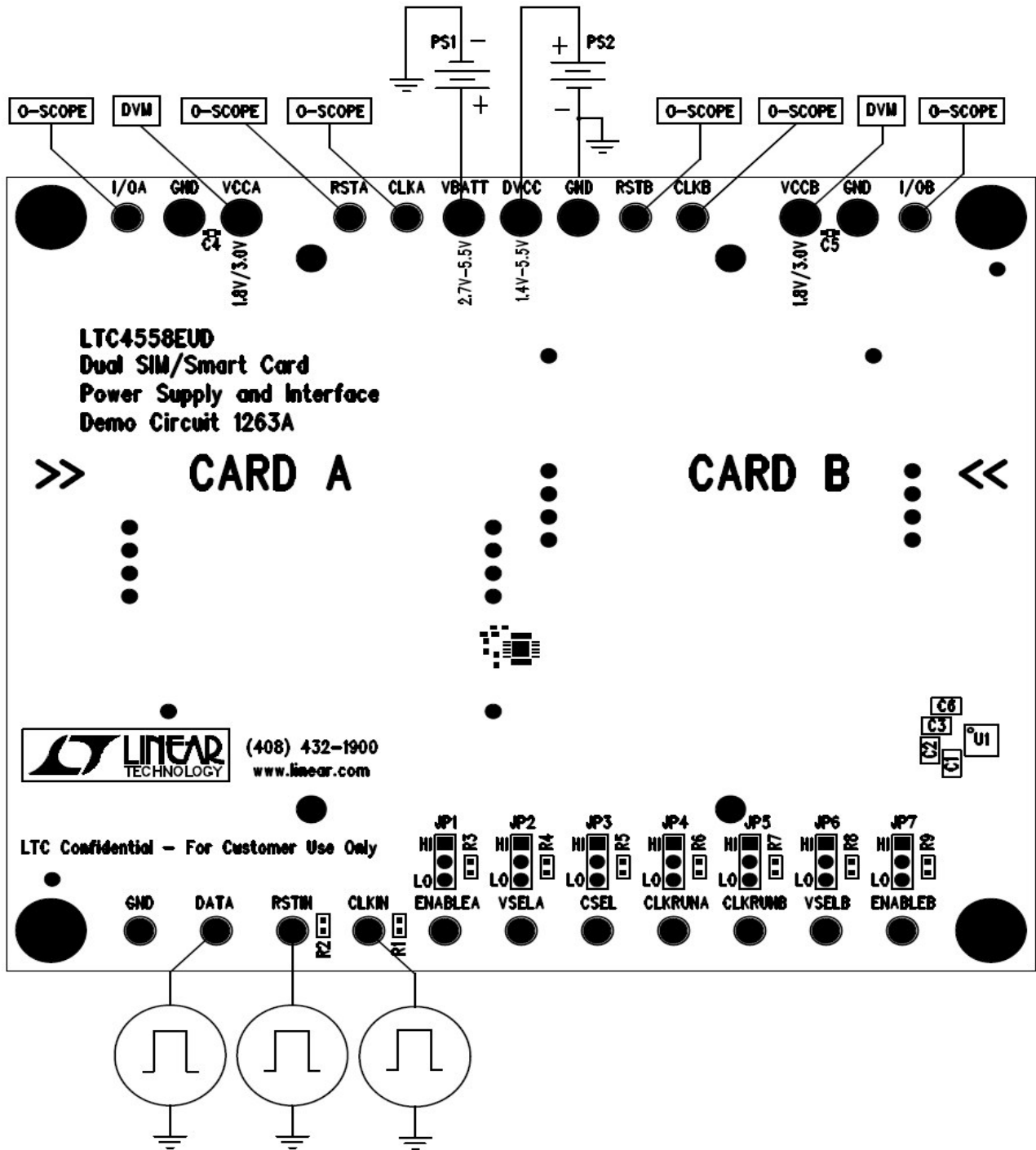

Figure 1. Proper Measurement Equipment Setup

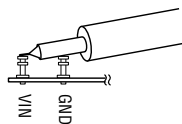
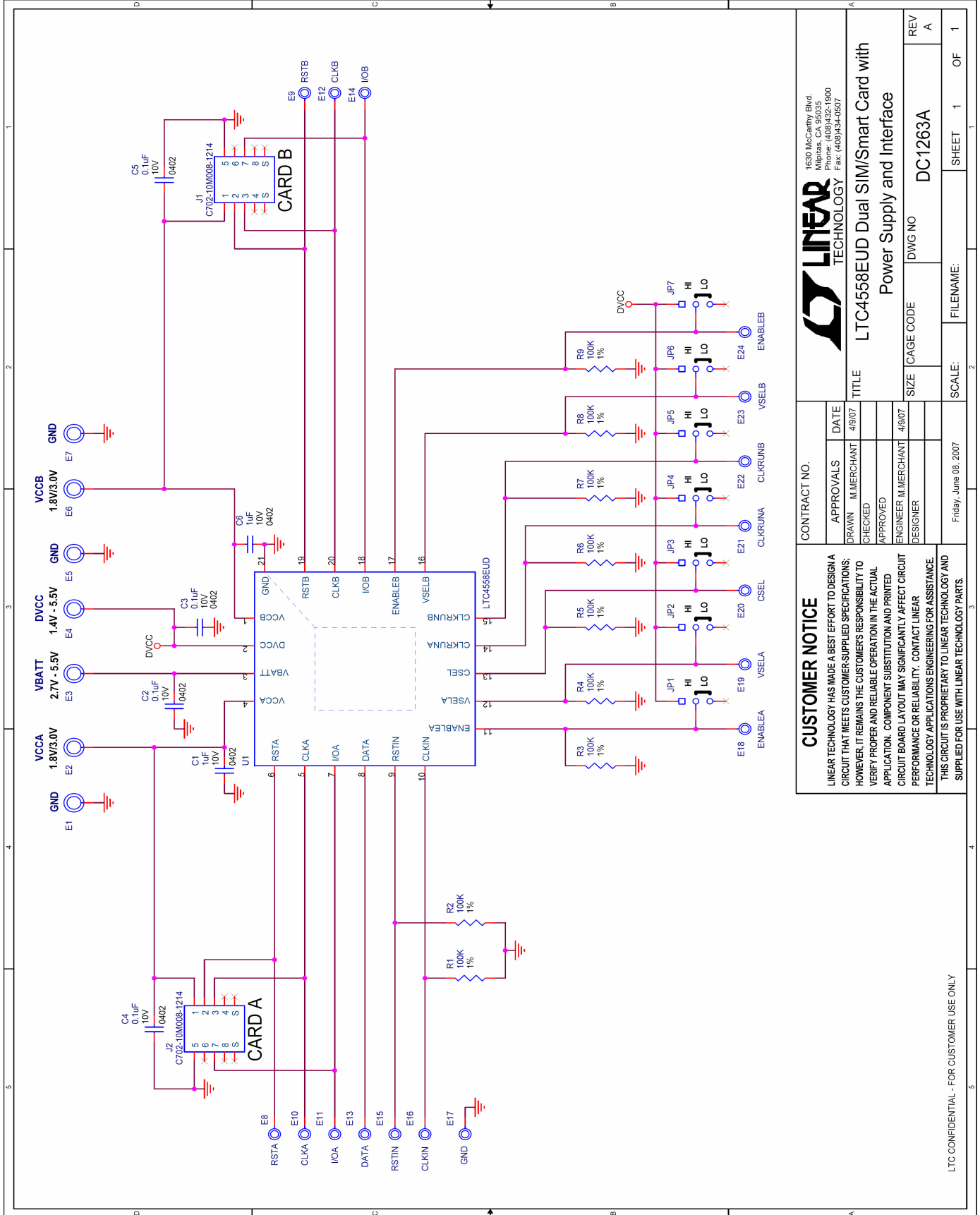

Figure 2. Measuring Input or Output Ripple



CONTRACT NO.		APPROVALS		DATE	
		DRAWN	M. MERCHANT	4/9/07	
		CHECKED			
		APPROVED			
		ENGINEER		M. MERCHANT	
		DESIGNER		4/9/07	
CUSTOMER NOTICE					
LINEAR TECHNOLOGY HAS MADE A BEST EFFORT TO DESIGN A CIRCUIT THAT MEETS CUSTOMER-SUPPLIED SPECIFICATIONS; HOWEVER, IT REMAINS THE CUSTOMER'S RESPONSIBILITY TO VERIFY PROPER AND RELIABLE OPERATION IN THE ACTUAL APPLICATION. COMPONENT SUBSTITUTION AND PRINTED CIRCUIT BOARD LAYOUT MAY SIGNIFICANTLY AFFECT CIRCUIT PERFORMANCE OR RELIABILITY. CONTACT LINEAR TECHNOLOGY APPLICATIONS ENGINEERING FOR ASSISTANCE.					
THIS CIRCUIT IS PROPRIETARY TO LINEAR TECHNOLOGY AND SUPPLIED FOR USE WITH LINEAR TECHNOLOGY PARTS.					

LINEAR TECHNOLOGY		1630 McCarthy Blvd. Folsom, CA 95630 Ph: (408)932-1600 Fax: (408)934-0507	
TITLE LTC4558EU Dual SIM/Smart Card with Power Supply and Interface			
SIZE	CAGE CODE	DWG NO	REV
		DC1263A	A
SCALE:		FILENAME:	SHEET 1 OF 1

Linear Technology Corporation
LTC4558EUD

Parts List

Bill of Material
Demo Circuit 1263A Rev A
6/27/2007

Item	Qty	Ref - Des	Desc	Manufacturer's Part Number
REQUIRED CIRCUIT COMPONENTS:				
1	2	C2, C3	CAP, CHIP 0.1uF, X5R, 10V, +/-10% 0402	MURATA, GRM155R61A104KA01
2	2	C1, C6	CAP, CHIP 1uF, X5R, 10V, +/-10% 0402	MURATA, GRM155R61A105KE15D
3	1	U1	IC, Dual SIM/Smart CARD Interface/Power Supply	LINEAR TECHNOLOGY, LTC4558EUD
ADDITIONAL DEMO BOARD CIRCUIT COMPONENTS:				
1	2	C4, C5	CAP, CHIP 0.1uF, X5R, 10V, +/-10% 0402	MURATA, GRM155R61A104K
2	9	R1-R9	Res, Chip 100K, 1/16W 1%	VISHAY, CRCW0402100KFKED
3	2	J1, J2	CONN, ISO LANDING PCB SMART CARD	AMPHENOL, C702-10M008-1214
HARDWARE FOR DEMO BOARD ONLY:				
1	7	E1-E7	TURRET, TEST PIN, 0.095"	MILL MAX, 2501-2-00-80-00-00-07-0
2	17	E8-E24	TURRET, TEST PIN, 0.061"	MILL MAX, 2308-2-00-80-00-00-07-0
3	7	JP1-JP7	JUMPER, 0.079"CC, 3PIN	SAMTEC, TMM-103-02-L-S
4	7	JP1-JP7	SHUNT	SAMTEC, 2SN-BK-G
5	4		STANDOFFS	KEYSTONE, 8831